



TS 01168:1.0

CRN EL 003

Standard

Low Voltage Distribution Earthing & Distribution Substation Earthing

Issue date: 12 July 2022

Effective date: 12 July 2022

Disclaimer

This document has been prepared by Transport for NSW (TfNSW) specifically for its own use and is also available for use by NSW public transport agencies for transport assets.

Any third parties considering use of this document should obtain their own independent professional advice about the appropriateness of using this document and the accuracy of its contents. TfNSW disclaims all responsibility and liability arising whether directly or indirectly out of or in connection with the contents or use of this document.

TfNSW makes no warranty or representation in relation to the accuracy, currency or adequacy of this document or that the document is fit for purpose.

The inclusion of any third party material in this document, does not represent an endorsement by TfNSW of any third party product or service.

For queries regarding this document, please email Transport for NSW Asset Management Branch at standards@transport.nsw.gov.au or visit www.transport.nsw.gov.au

Document information

Owner: Director Energy Networks and Systems, Asset Management, Safety, Environment and Regulation
Mode Heavy rail
Discipline Electrical

Document history

Revision	Effective date	Summary of changes
3.0	July 2022	TfNSW template applied.

Table of contents

1. Supply from a High Voltage Network	5
2. Supply from Local Electricity Distributor's Network	6
2.1. General	6
2.2. The Local Electricity Distributor's Point of Supply	6
2.3. Isolating Transformer	6
2.4. Supply Main Switchboard	8
2.5. Voltage Operated ELCB from a Local Electricity Distributor	8
3. Back-up Supply with Change-over Contactor	8
4. Distribution Substation Earthing	10
4.1. General	10
4.2. Separate Earthing System	10
4.3. Earthing Grid	12
4.4. Earthing Connections	13
4.5. High Voltage Earth Conductors	13
4.6. Main Low Voltage Earth Conductor	14
4.7. Equipment Earthing	14
4.8. Substation on Timber Pole	15
4.9. Fibreglass Pad mount Substation	18
4.10. Ground Mounted Substation	18
4.11. Distribution Substation with Combined Earthing System	19

List of figures

Figure 1 Supply from a High Voltage Network	6
Figure 2 Supply from Local Electrical Distributors Network	7
Figure 3 Back-up Supply with Change-over Contactor	9

1. Supply from a High Voltage Network

The low voltage earth grid is provided by electrodes located at the Distribution Substation; refer to CRN EL 003 – Distribution Substation Earthing.

The supply main switchboard which may be located at the Distribution Substation or at the installation, e.g., railway station, will have the earth bar and neutral bar connected together. This connection must be the only earth-neutral connection for the whole electrical installation supplied from this substation. Refer to figure 1 below. The transformer mains active and neutral conductors shall be a minimum of 25 mm² copper of single core double insulated (SDI, 0.6/1.0 kV) construction from the Distribution Substation to the supply main switchboard. If the active and neutral conductors are to be switched, then all conductors must be switched simultaneously.

If there is a substantial metallic water pipe nearby then the earth bar of the supply main switchboard is to be bonded to it with a conductor of the same size as the main earth conductor but need not be larger than 70 mm² copper. The bond conductor is to be effectively protected from mechanical damage as detailed in CRN EL 002 – Low Voltage Installations Earthing. The supply main switchboard shall be clearly labelled with the location of the water pipe connection and the appropriate earth link shall be clearly labelled “water pipe bond”.

Note: A 2 m distance shall be maintained between any low voltage earthed equipment and overhead wire structures which are not bonded to the low voltage earthing system.

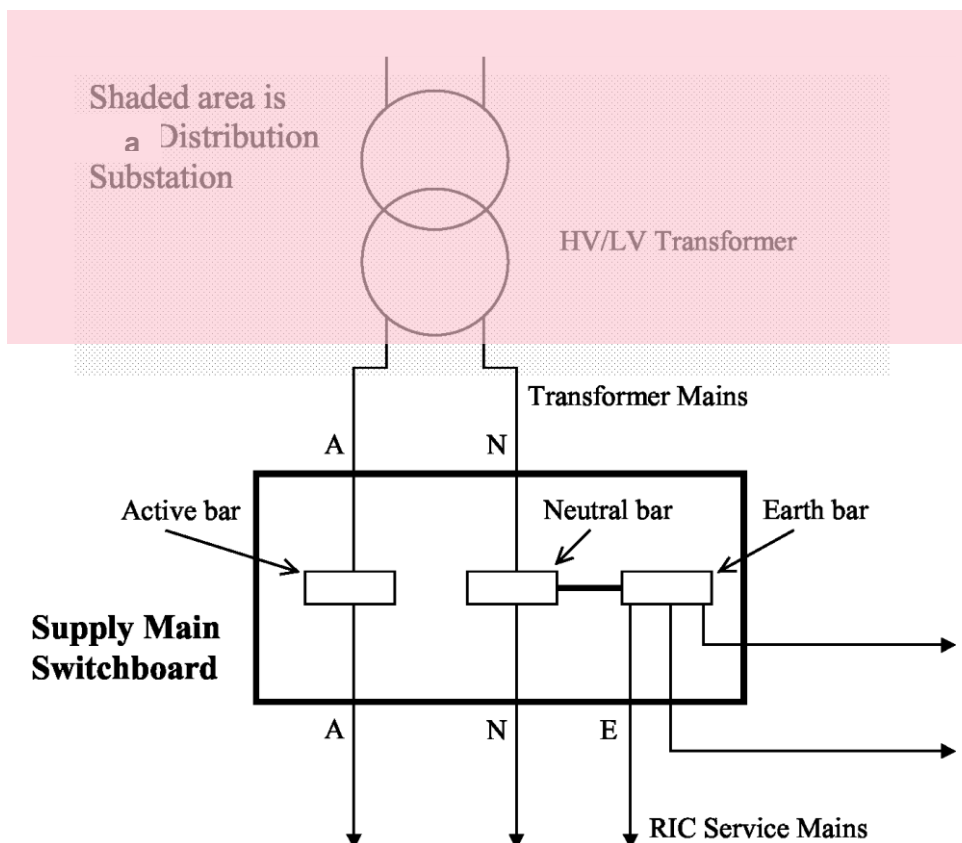

Figure 1 Supply from a High Voltage Network

2. Supply from Local Electricity Distributor's Network

2.1. General

The MEN system of a local Electricity Distributor must not be allowed to pick up appreciable dc leakage current. The recognised method of achieving this is to ensure the earth and neutral of the MEN supply is physically isolated from any part of the supplied installation, including earthed metalwork (such as pipes, fences, overhead earth wires or troughing).

This document is based on the use of an isolating transformer to separate the local Electricity Distributor's MEN earth and neutral from the URLRL CRN distribution systems direct earthing system. Refer to figure 2 below. Where the local Electricity Distributor supply is from a dedicated substation with separate high and low voltage earthing systems and with no MEN connections then there shall be no requirement for an isolating transformer.

2.2. The Local Electricity Distributor's Point of Supply

The supply from the service line shall be taken at a point as close as practicable to the boundary of the 'railway corridor' maintaining a clearance of 2 m from the boundary fence or any other earthed metalwork. This may be by the use of a non-metallic meter board, which will negate the need for earthing the meter board, or one of the methods contained in Specification PSD 08 - "Low Voltage Installations Earthing".

The consumer's mains and the service equipment, including the earthing of the meter board and the neutral, shall be as prescribed by the local Electricity Distributor. The local Electricity Distributor's earth electrode shall be located as far as practicable but in any case, not closer than 3m from the closest electrified rail and any other metalwork associated with the installation, such as an overhead wire structure footing, fence or signal cable troughing.

2.3. Isolating Transformer

An isolating transformer shall be connected between the local Electricity Distributor's service equipment and the supply main switchboard to physically isolate the earth and neutral of the MEN supply from any part of the URLRL CRN distribution system, including earthed metalwork (such as pipes, fences, overhead earth wires or troughing).

The isolating transformer shall comply with SRA Specification A-844. The transformer shall be installed with a sign prominently displayed on its case stating that it is double insulated and conforms to AS 3108.

The transformer mains active and neutral shall be a minimum size of 25 mm² copper of single core double insulated (SDI, 0.6/1.0 kV) construction up until the neutral-earth connection for the URLRL CRN distribution system at the supply main switchboard. If the active and neutral conductors are to be switched before the neutral-earth connection, then all conductors must be switched simultaneously.

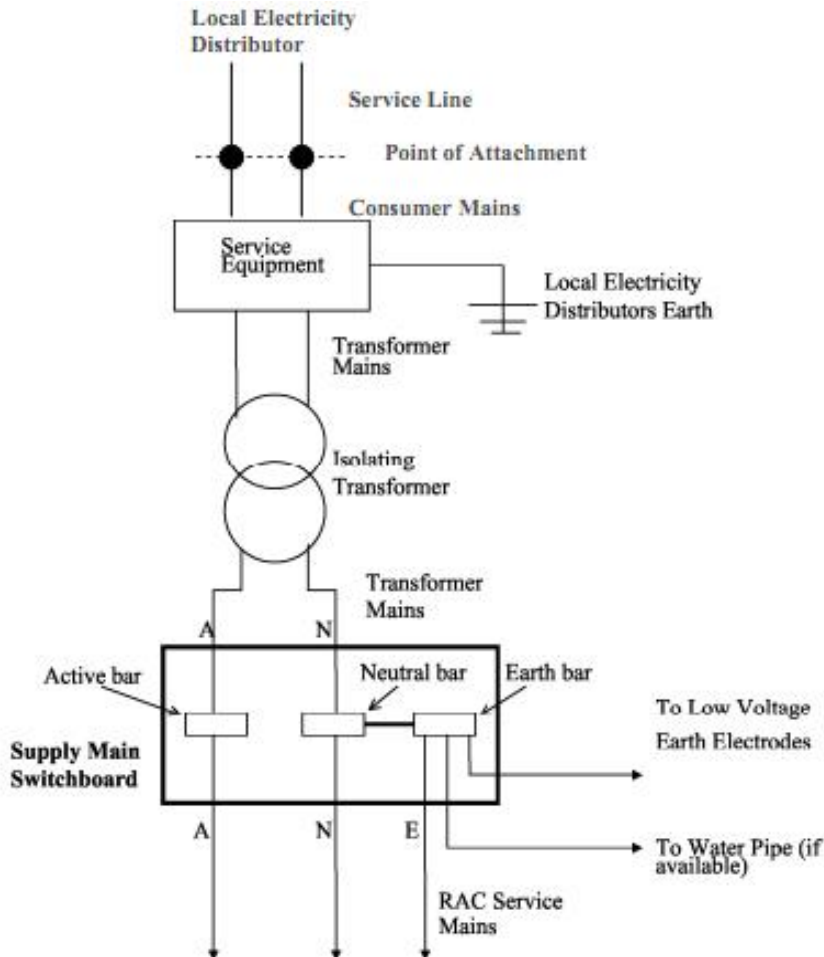

Figure 2 Supply from Local Electrical Distributors Network

In the situation described above no connection shall be made to the isolating transformer screen.

The case of the transformer is not to be earthed.

CAUTION

For 120 V signalling supplies the neutral of the isolating transformer secondary winding is not directly connected to earth and the isolating transformer screen must be connected to the supply earth (and neutral). This connection is required to provide a direct path to earth to ensure the operation of the primary side protection if the double insulation of the isolating transformer breaks down. Refer to CRN EL 002 – Low Voltage Installations Earthing.

2.4. Supply Main Switchboard

The supply main switchboard is the first switchboard after the isolating transformer terminals. The supply main switchboard is the location to establish the one and only connection between earth and neutral.

CAUTION

For 120 V signalling supplies there shall not be any connection between earth and neutral, except as authorised by the Principal Signal Engineer. Refer to CRN EL 002 – Low Voltage Installations Earthing.

In the situation where the local Electricity Distributor supply is a back-up to an URLRL CRN supply the supply main switchboard is a part of the URLRL CRN infrastructure. The local Electricity distributor's supply line shall connect through the isolating transformer directly to the change-over contactor. Refer to section 3.

2.5. Voltage Operated ELCB from a Local Electricity Distributor

This system is encountered only in the older installations built before 1988. No new voltage operated earth leakage circuit breaker installations are to be built. The arrangement is shown in Drawing E/3 8221.

3. Back-up Supply with Change-over Contactor

Critical installations usually have two sources of supply, a normal local electricity distributor supply with a back-up from a motor generator connected through an automatic change-over contactor.

The local electricity supply shall be connected as described in section 1 with the automatic changeover contactor fed from the main supply switchboard. The motor generator supply shall be connected as described in section 2, but will not have a supply main switchboard. The transformer mains shall be connected directly from the isolating transformer to the change-over panel.

Refer to figure 3 below.

It is essential at these locations that the following points are taken into account when designing the earthing for the automatic changeover panel.

- There must be only one earth-neutral connection which is to be located on the URLRL CRN supply main switchboard. This connection must not be broken unless both supplies are disconnected.

- There must be a solid neutral and solid earth connection to the URLRL CRN supply main switchboard at all times. The change-over panel should not break these conductors during operation.
- The local Electricity Distributors active and neutral conductors shall be connected and disconnected (switched) simultaneously either at the service equipment or at the changeover panel.
- A back-feed must not be possible when one supply is out of service for maintenance.

Note: there are some signal locations where the normal supply is from a local Electricity Distributor with a back-up supply, through an automatic change-over contactor, from a diesel generator. In this situation the normal supply shall be as described in section 2, including the supply main switchboard and the diesel generator shall be as described in CRN EL 002 – Low Voltage Installations Earthing.

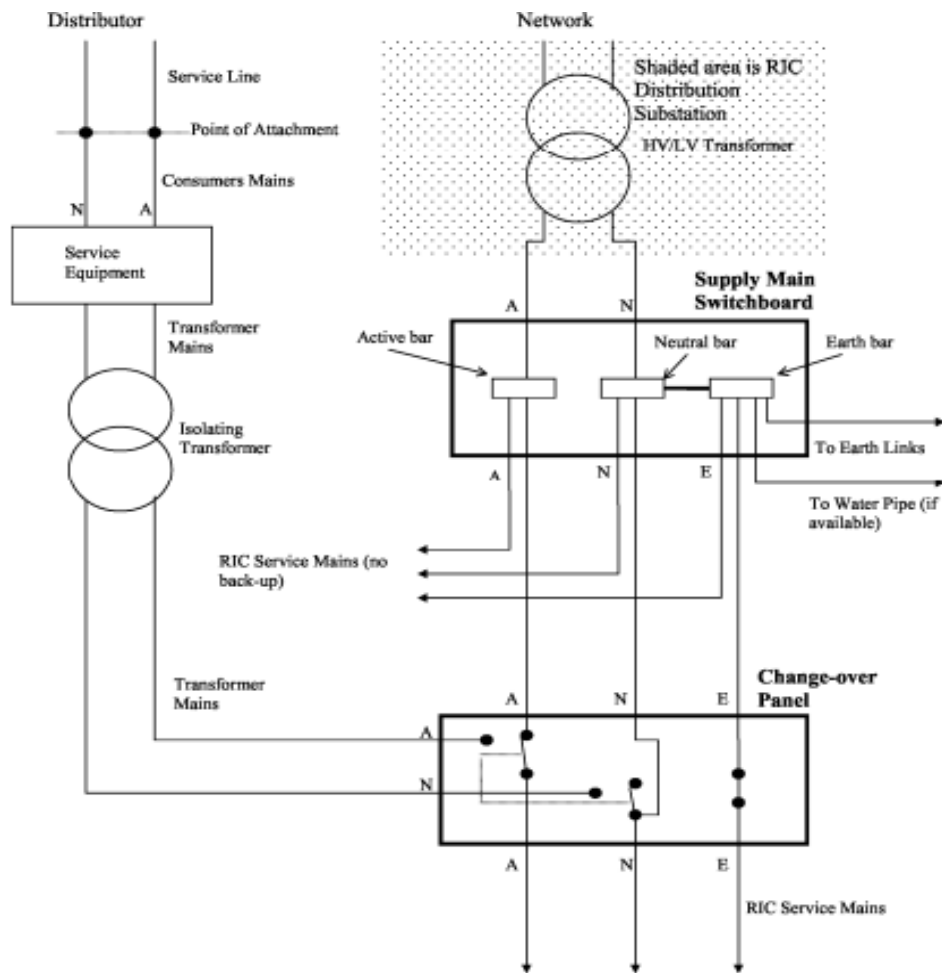

Figure 3 Back-up Supply with Change-over Contactor

4. Distribution Substation Earthing

4.1. General

Distribution Substations are widespread and have a relatively low fault level so that a general design can be followed. If the earth grid resistance is kept down to the level specified, then the prospective touch and step voltages are of a safe order of magnitude for maintenance staff following work procedures and for the general public. This policy is based on 'frequented locations' as defined in EC 5 - Guide to Protective Earthing - Electricity Council of N.S.W. - 1992.

Generally, it is Sydney Trains policy at Distribution Substations, except underground substations, to use two separate and distinct earthing systems; one for the high voltage and the other for the low voltage equipment. The main reasons for not using combined high and low voltage earths are:

- A combined earthing system provides a relatively low (1) earth path for dc leakage current. This could permit stray current to flow between earths at a local substation and a traction substation if a spark gap on a structure operates and becomes short circuited.
- The difficulty in obtaining the required low earth impedance of 1. The C] URLRL CRN system does not have sufficient multiple earth-neutral connections along its reticulated neutral as an MEN system and so it is much more difficult to obtain a low resistance.

Note: Separate earth systems can create a major problem with touch and step voltages. This problem is addressed by some of the design criteria in this document.

4.2. Separate Earthing System

The separate system of earthing requires, under the SAA Wiring Rules (AS 3000

Clause 8.12.5.2), that the earth connections of the earthing system be located, installed and maintained so that the resistance to earth does not exceed the following:

(i) High voltage system: 30 (ii) Low voltage system:

Aggregate transformer rating up to 50 kVA: 30Ω

Aggregate transformer rating over 50kVA but not more than 500 kVA: 15Ω

Aggregate transformer rating over 500 kVA: 10Ω

The separation clearances that must be maintained between the high voltage and low voltage earth systems is covered in AS 3000 – 1991 Clause 8.12.5.5 namely:

1) *Electrode and electrode connections:* Electrodes of the high voltage earthing system shall be installed not less than two metres from those of the low voltage system. This separation shall

also apply to conductors connected to the electrodes unless the conductors are suitably insulated to at least 0.6/1 kV insulation level.

2) *Conductors and metallic parts*: Unless insulated to at least 0.6/1 kV insulation level, any conductors or metallic parts which are connected to the high voltage earthing system shall be provided with a clearance of not less than 35 mm from any conductors or metallic parts which are connected to the low voltage system, except that this clearance shall not apply to an approved lightning protection neutral spark-gap.

Equipment to be connected to the high voltage earthing system:

- High voltage earth grid.
- All accessible exposed metal parts containing or supporting high voltage conductors (including metal parts mechanically connected to the exposed metal parts).
- Exposed metalwork of all high voltage equipment, including air break switch frames.
- High voltage surge protection devices.
- High voltage cable sheaths/screens/armouring.
- Equipotential loop (where required).

Equipment to be individually connected to the low voltage earth bar on the first main switchboard (the supply main switchboard):

- Low voltage earth grid.
- Transformer low voltage neutral (connected via low voltage neutral bar).
- Low voltage surge protection devices.
- Exposed metal associated only with the low voltage system, refer to separate section for low voltage switchboards associated with pole-mounted transformers.
- Nearby metallic water pipes.

4.2.1. Combined Earthing System

If a combined earthing system is used, that is the high voltage and low voltage equipment is earthed to a common terminal bar, then the combined earthing system shall have a resistance to earth not greater than 1 and must still be 3 0 or less even when part of the earthing system is removed, including temporary disconnections. For further information refer to AS 3000 section 8.12, in particular 8.12.4, and RailCorp Specification EP12100010SP - "System Substation Earthing" available through the ASA website

4.3. Earthing Grid

4.3.1. Electrodes

4.3.1.1 Standard Electrode

The standard earth electrode for a Distribution Substation in the ARTC system is a 2.4 metre x 15 mm diameter, tapered end jointed copper clad rod, for example ALM - Dulmison part numbers, CTE 1524. This is used as it is an industry wide standard. A minimum of two electrodes are required for each separate earthing system.

Other electrodes may be used where required, refer to section 4.3.1.3.

The current rating of the earthing electrode is 5 kA for 1 second when tested in free air in an ambient of 15C to 25C without exceeding a temperature rise of 350C.

4.3.1.2 Electrode Spacing

The requirements for the number and depth of electrodes is dependent on the local conditions. However, a minimum of two electrodes must be installed for each separate earthing system even if the resistance of one electrode is sufficiently low. This is to provide a factor of safety against mechanical failure.

The depth of the electrodes will be determined by local conditions, resistivity of the area and space available for electrodes. Electrodes which are to be connected together to form an earthing grid shall be positioned so that their spacing is equal to or greater than their length but the spacing shall not exceed twice the length.

4.3.1.3 Installation of Electrodes

The electrodes shall be driven where conditions are suitable, otherwise use drilled holes (50 mm diameter) back filled with a conducting medium mixture, for example bentonite, gypsum and sodium sulphate (50%, 45% and 5% by weight respectively) mixed to AS 2239 - Cathodic Protection, or similar. The top of each electrode is to finish 200 mm below ground level.

Where conditions are such that it is advantageous to use two 1.2 m electrodes joined together, this is acceptable. Where the electrode is being or is likely to be damaged in the installation process, the drilled hole method of installation shall be adopted.

Where deep earthing is required the earthing electrode can be a 6 m length of thick copper tube (14.29 mm outside diameter, 11.03 mm inside diameter, this internal dimension will allow a 70 mm² conductor to be a close fit for a crimped joint). The longer electrodes may need to be used as the soil resistivity is frequently found to be lower at greater depths.

Each earth electrode is to have a collar installed with the inside of the collar backfilled with earth. A lid is to be placed over the collar.

4.4. Earthing Connections

4.4.1. General

Typical connection diagrams are shown in drawing C/79930. In general, C clamps may be used for connections on both the high voltage and low voltage earthing systems. An exothermic welding process such as a cadweld may also be used, if preferred.

4.4.2. Driven Electrode Connection

The main high and low voltage earthing conductors are to be connected to the first driven electrode by use of a double saddle clamp. The second and any additional electrodes are to be connected within the collar of the preceding electrode. This connection is to be made using a compress-on copper connection ('C' clamp) or a tee exothermic welded joint. The compress-on or tee cad-welded joint will allow extension of the main earthing conductor without breaking the main earth connection on the line side of the first electrode.

The main low voltage earthing conductor between the supply main switchboard and the first electrode is to be insulated to 0.6/1.0 kV. The extensions to the remaining electrodes are to be uninsulated conductors.

4.4.3. Bored Hole Electrode Connection

The main high and low voltage earthing conductors are to be connected to the first electrode by crimping. The earth conductor will need 75 mm of insulation removed, the 75 mm of bare 70 mm² conductor inserted inside the copper tube electrode and either of the following crimp methods used:

- Hydraulic crimp: 2 crimps with a 70 mm² die over the 75 mm of insert.
- Hand crimp: 5 crimps over the 75 mm of insert.

The remaining electrodes are to be connected using uninsulated conductor and the compress-on system or tee exothermic weld method detailed for the driven electrode.

4.5. High Voltage Earth Conductors

The size of the high voltage earthing conductors is determined by the earth fault level and shall be in accordance with AS 3000, clause 7.8.10.7.2, but in any case, shall be not smaller than 70 mm² copper.

4.6. Main Low Voltage Earth Conductor

The main low voltage earthing conductor is between the low voltage earth electrodes and the supply main switchboard earth bar.

The size of the main earthing conductor shall be in accordance with AS 3000 clause

7.8.10.7.3. Conductors used for connection to earth electrodes shall not be smaller than 25 mm² copper.

The main low voltage earthing conductor is to be insulated green/yellow (with 0.6/1 kV rating) until connection of the first low voltage electrode. The low voltage main earthing conductor connecting the remaining electrodes is to be bare copper conductor, refer to section 2.2.2.

4.7. Equipment Earthing

4.7.1. Surge Arresters

The connection between the earth side of the high voltage arrester and the earth side of the equipment being protected, such as a transformer tank, must be as short as possible (the same applies to the live side of the surge arrester). The resistance connection to remote earth is not critical to the surge arrester operation but it is important to consider the touch potentials during the surge arrester operation.

If a low voltage arrester is installed at a substation, the earth side must be connected to the low voltage neutral. This is because the leads of the arrester should be kept as short as practicable, and the nearest low voltage earth is at the supply main switchboard.

Under no circumstances should the low voltage arrester earth side be connected to the transformer tank (high voltage earth) otherwise failure of the high voltage interturn insulation may occur if there is a lightning strike on the high voltage. This can arise when a strike on the high voltage causes the tank potential to rise above earth, the low voltage arrester may then operate and discharge surge current through the low voltage winding to the low voltage earth. This can cause very high voltages to be induced in the high voltage winding causing its insulation to fail between turns.

A failure of the low voltage arrester could result in the tank being livened at 240 V.

4.7.2. Cable Sheath and Armour

All high voltage cable sheaths and armouring must be connected to the main high voltage earth. The connection is made at the high voltage earth bar in the case of substations with separate earthing and at the common earth bar in the case of substations with combined earthing.

4.8. Substation on Timber Pole

4.8.1. General

Refer to drawing A3 90094 when low voltage earthed or A3 90095 when low voltage unearthed.

4.8.2. Air Break Switch Frame

The air break switch frame is only connected to earth when there is equipment mounted at the top of the pole, eg transformer or surge arrester.

The earth connection point on the air break switch frame is the connecting point for the earth conductors for the surge arrester, earthing switch, transformer tank and also connects to the main earthing conductor where a main earth conductor runs down the pole from an overhead earth wire. Where no overhead earth wire exists the earthing conductor from the air break switch frame becomes the main high voltage earth conductor.

For a line air break switch where the air break switch frame is not earthed refer to section 4.8.14

4.8.3. Air Break Switch Handle

The air break switch handle is to be connected to the main high voltage earth conductor by a flexible copper braid such as ALM-Dulmison cat. no. RA 40300 or a connector with equivalent current carrying capacity and equivalent mechanical strength and flexibility.

The air break switch operating handle must also be connected to an equipotential mat or buried loop located directly below the handle. Refer to section 4.8.4.

4.8.4. Equipotential Mat or Loop

An equipotential mat or buried loop must be placed directly below the operating handle of an air break switch such that the operator must stand on the mat or within the loop to effectively operate the equipment. This will reduce the risk of an operator suffering an electric shock in the case of a fault current flowing through the operating linkage and causing a voltage difference between the operating handle and the ground whilst an operator is in a critical position.

An equipotential mat consists of a non-slip galvanised mesh or steel plate securely fixed above the level of the ground to ensure that it is not inadvertently covered by the surface material.

Although the effectiveness of the mat will not be affected by a layer of dirt, it must still be visible to the operator to ensure it is in good condition. Where the ground level is sloping the operators mat can be installed by concreting legs, permanently attached at each corner of the mat, to a depth required to effect a permanent stable support (a minimum of 300 mm will be necessary).

Alternatively, a buried equipotential loop can be made from a minimum bare 70 mm² copper conductor but must not be formed from the main earthing conductor. The loop is placed around the pole so that an operator will stand within the loop when operating the air break switch

handle. The conductor is to be buried between 100 and 150 mm below ground level with a diameter of 2500 mm.

The equipotential mat or buried loop must be connected to the air break switch operating handle. Refer to section 4.8.3.

4.8.5. Air Break Switch Operating Rod

All air break switch-operating mechanisms must be fitted with an insulated section such that the top of the insulating section should be a minimum of 2400 mm above the operating handle. This is for additional protection to section 4.8.3. There are three options of insulating material as follows:

- Oregon or Tallow wood 50 mm x 50 mm dressed with chamfered ends, 1200 mm (minimum) long for voltages up to and including 33 kV or 2400 mm (minimum) long for voltages exceeding 33 kV.
- An ultraviolet inhibited fibreglass rod of equal mechanical strength and length to the wood.
- A post type insulator of the same phase to earth voltage rating as the air break switch. The top of the insulator should be a minimum of 2400 mm above the operating handle.

4.8.6. Earthing Switch

An earthing switch shall be used to earth both sides of a high voltage fuse to increase the safety for an operator when replacing a fuse.

There are two types of earthing switches that shall be used:

- (i) Operating rod

Transformer locations connected to the 11 kV system shall have an earthing operating rod part way up the ladder. It shall be positioned so that the operator cannot easily proceed past the point without earthing the high voltage supply

- (ii) Dual operating handles

Transformer locations connected to the 33 kV system shall have an operating handle adjacent to and mechanically interlocked with the air break switch handle. A safety sign shall be installed at these locations, see section 4.8.9.

4.8.7. Transformer Tank

The transformer tank is to be connected to the main high voltage earth wire at the air break switch frame.

4.8.8. Access Ladder

Metal ladders constructed of more than one individual section must have a separate earth connection for every section of the ladder. The most common type of ladder in use in the ARTC system consists of two sections, the top section being fixed in position and the lower section folding to restrict access.

The connection to the top section of the ladder should be close to the top of the ladder to reduce the chance of a touch voltage between the top step of the ladder and the air break switch frame, under fault conditions. The connection to the bottom section of the ladder should be connected close to the bottom of the ladder, for similar reasons, but must be higher than the Earthing Test Links otherwise the links will be short-circuited by the two earth connections of the ladder in the case of a folding style ladder when the ladder is in the unfolded position.

Fibreglass ladders and other ladders made of non-conductive materials are not required to be connected to earth.

4.8.9. Signs

All pole mounted transformer installations with a primary side voltage of 33 kV and above require a metal notice plate reading "Open air break switch and close earth switch before ascending" to be provided at the bottom of the ladder as unlike the 11 kV locations there is no physical barrier

4.8.10. Test Links

Where the supply main switchboard (and thus the low voltage earth electrode system connection) is mounted on the same pole as a substation, test links for both the high voltage and low voltage earthing systems shall be provided. The links shall be installed:

- to allow either the low voltage or high voltage earth electrodes to be disconnected from their respective earthing systems for the purpose of periodical testing over the life of the substation. The substation may remain
- on-line and a link arrangement is to be provided whereby the two systems are temporarily connected. The earth electrode system to be under test may then be disconnected; both high voltage and low voltage earthing systems are then earthed by the other electrode network. This link arrangement is to be housed in an insulated box (or equivalent) to protect against touch potentials between the two earth systems.
- such that conductors or metallic parts of the low voltage earthing system are insulated to at least 0.6/1 kV insulation level (AS 3000 Clause 8.12.5.5(b)).
- to be accessible for test purposes and mounted approximately 2.7 m from ground level. This height allows for clearance above the mechanical protection of the earthing conductors.

- with clear labelling as to the respective earthing system.
- Where the low voltage is an unearthed system test links must be provided for the high voltage earth system. The high voltage must be isolated when testing when in this situation.

4.8.11. Mechanical protection of earthing conductors

The main high and low voltage earthing conductors, that is any 70 mm² earthing conductors, shall be effectively protected from mechanical damage from ground level to a height of 2.4 m. This protection may be in the form of a metallic conduit, tallow wood batten or may be achieved by installing the main earth conductor in PVC conduit and protecting the PVC by a steel sleeve.

4.8.12. Switchboards (Pole Mounted)

All new pole mounted substation installations are to be provided with non metallic switchboards for the housing of low voltage equipment.

Existing installations with metallic switchboards may make use of an insulating coating such as "Emerclad". Once correctly applied to the exterior surface of the switchboard the risk of a dangerous touch voltage between earthing systems will be reduced to an acceptable level. However, an economic assessment must be made of the maintainability requirements of each location based on local knowledge, such as likelihood of vandalism, and compared to the option of replacing the board with a non-metallic enclosure.

4.8.13. Automatic Reclosers

The metal case of a pole mounted auto-recloser should be connected to the main high voltage earth.

4.8.14. Line Air Break Switch

A line air break switch used only for sectionalising a feeder shall not have its air break switch frame earthed as there is no equipment requiring the earth. This requirement remains even if an overhead wire is associated with the line, that is, a tee off from the overhead wire shall not be required.

4.9. Fibreglass Pad mount Substation

Refer to drawing C/87206 for general layout.

4.10. Ground Mounted Substation

Standard requirements for this configuration have not yet been determined.

4.11. Distribution Substation with Combined Earthing System

Distribution Substations with combined earthing systems require a more rigorous earthing design based on Specification EP12100010SP - "System Substation Earthing".

A combined earthing system should only be used at a Distribution Substation where it is difficult to ensure that there are no unintentional connections between the two separate earth systems leading to the possibility of dangerous touch voltages. This situation is usually encountered at an underground location. In addition, as an underground location is cable fed the cable sheaths are connected to adjacent substations, usually System Substations, and these connections to the associated earthing systems of the adjacent substations can give rise to transferred prospective touch voltages at the Distribution Substation if the resistance of the local earth mat and the resistance of the cable and its' sheath are not carefully considered in the earthing calculations.

The benefit of this situation is that the necessary low resistance earth of 1 f o r a combined earthing system is easily achieved by utilizing the cable sheaths.

Examples of existing substations that are based on this principle are the substations for the City and Eastern Suburbs underground railway stations. Keeping the high voltage and low voltage earthing systems separate to minimise traction return leakage current problems is not justified at these locations. The drawing for the earthing arrangement of the Eastern Suburbs Railway, D/80605, can be used until a generic drawing is produced.

For further information refer to AS 3000 section 8.12, in particular 8.12.4