

# Traffic signal design

Section 14 – Signalised mid-block marked footcrossings



The traffic signal design guidelines have been developed to assist in designing traffic control signals.

The guidelines are to comprise 16 sections and 5 appendices. These are initially being released individually and in no specific order. The sections which are to be released are as follows:

<b>Part</b>	<b>Title</b>
Section 1	Investigation
Section 2	Warrants
Section 3	Design Process
Section 4	Plan Requirements
Section 5	Geometry
Section 6	Pavement Marking
Section 7	Phasing and Signal Group Display Sequence
Section 8	Lanterns
Section 9	Posts
Section 10	Signs
Section 11	Detectors
Section 12	Controller
Section 13	Provision for Future Facilities
Section 14	Signalised Mid-block Marked Footcrossings
Section 15	Special Situations
Section 16	References
Appendix A	Design Plan Checklist
Appendix B	Traffic Signal Symbols
Appendix C	Location and Function of Lanterns
Appendix D	Location and Dimensions of Components
Appendix E	Left Turn on Red
Appendix F	Level Crossing Interface – Concept of Operations
Appendix G	Level Crossing Interface – Traffic Signal Design Guidance

To determine which sections are currently available go to:

[www.rta.nsw.gov.au/doingbusinesswithus/downloads/technicalmanuals/trafficsignaldesign\\_dll.html](http://www.rta.nsw.gov.au/doingbusinesswithus/downloads/technicalmanuals/trafficsignaldesign_dll.html)

The information contained in the various parts is intended to be used as a guide to good practice. Discretion and judgement should be exercised in the light of the many factors that may influence the design of traffic signals at any particular site. The guidelines make reference, where relevant, to current Australian Standards and are intended to supplement and otherwise assist in their interpretation and application.

# Traffic Signal Design

## Section 14

# SIGNALISED MID-BLOCK MARKED FOOT CROSSINGS

**Special Note:**

As of 17 January 2011, the RTA is adopting the Austroads Guides (Guide to Traffic Management) and Australian Standards (AS 1742, 1743 & 2890) as its primary technical references.

An RTA Supplement has been developed for each Part of the Guide to Traffic Management and relevant Australian Standard. The Supplements document any **mandatory** RTA practice and any complementary guidelines which need to be considered.

The RTA Supplements **must** be referred to prior to using any reference material.

This RTA document is a complementary guideline. Therefore if any conflict arises, the RTA Supplements, the Austroads Guides and the Australian Standards are to prevail.

The RTA Supplements are located on the RTA website at [www.rta.nsw.gov.au](http://www.rta.nsw.gov.au)





**Roads and Traffic Authority**

[www.rta.nsw.gov.au](http://www.rta.nsw.gov.au)

**VERSION:** 1.0  
**ISSUED:** February 2008  
**AMENDMENTS:** Refer to Amendment Record

**APPROVED BY:**

**SIGNED**

Phil Margison  
General Manager  
Traffic Management

**SIGNED**

Steve Levett  
A/General Manager  
Safer Roads

**AUTHORISED FOR USE BY:**

**SIGNED**

Michael Bushby  
Director  
Network Management

© 2008 Roads and Traffic Authority NSW

Extracts from these guidelines may be reproduced providing the subject is kept in context and the source is acknowledged.

Every effort has been made to supply complete and accurate information. However RTA, NSW assumes no responsibility for its use.

All trade name references herein are either trademarks or registered trademarks of their respective companies.

***For policy and technical enquiries regarding these guidelines please contact:***

Traffic Management Branch  
Email: [technical\\_directions\\_publication@rta.nsw.gov.au](mailto:technical_directions_publication@rta.nsw.gov.au)

***To access electronic copies of these and other guidelines go to:***

[www.rta.nsw.gov.au/doingbusinesswithus/downloads/technicalmanuals/technicalmanuals\\_d11.html](http://www.rta.nsw.gov.au/doingbusinesswithus/downloads/technicalmanuals/technicalmanuals_d11.html)

***For the latest amendments (if any) to these guidelines go to:***

[www.rta.nsw.gov.au/doingbusinesswithus/downloads/technicalmanuals/trafficsignaldesign\\_d11.html](http://www.rta.nsw.gov.au/doingbusinesswithus/downloads/technicalmanuals/trafficsignaldesign_d11.html)

ISBN 978-1-921242-95-3 (Electronic only)  
RTA/Pub. 08.092



## Contents

14.1	INTRODUCTION .....	14-1
14.2	ONE-STAGE CROSSINGS.....	14-1
14.3	TWO-STAGE (OFFSET) CROSSINGS.....	14-2
14.4	PELICAN CROSSINGS.....	14-3

SUPERSEDED

### Amendment record

Please note that the following updates have been made to this document.

Amendment No	Page	Description	Issued	Approved By
1	Various	Figures amended to reflect new marked foot crossing markings.	August 2008	R O'Keefe Mgr Policies & Guidelines
2	14-2	Text dealing with the use of pedestrian fencing amended.	May 2009	R O'Keefe Mgr Policies & Guidelines
	14-3	Labelling of Post 4 in Figure 14.3 amended & note added.		
3	14-3	Section 14.4 amended	December 2010	R O'Keefe Mgr Traffic Policies, Guidelines & Legislation
4	14-3	Section 14.3 amended	August 2012	R O'Keefe Mgr Traffic Policies, Guidelines & Legislation

## 14.1 INTRODUCTION

Warrants for the provision of signalised mid-block marked foot crossings are given in Section 2 [Warrants](#). Once the decision to provide a signalised mid-block marked foot crossing has been made, the designer must choose the type of crossing and the best location for it. Signalised marked foot crossings, mid-block or otherwise, must not be used in association with raised medians or thresholds.

Signalised mid-block marked foot crossings must be located a minimum of 30 m from any side streets. This is to avoid side-street traffic misinterpreting the traffic signals as controlling their movement. It also prevents the situation where a vehicle enters the main road just as the signals change to the pedestrian phase and the driver of the entering vehicle is unaware of the change or unable to react in time. Exceptions to this requirement may be granted by the Manager Network Operations.

Signalised mid-block marked foot crossing must be avoided within 130 m of an adjacent signalised intersection. This is to avoid unintended and possibly misinterpreted sighting of the adjacent intersection signals. It is also to keep the total number of signal sites to a manageable level and avoid unnecessary impact on the overall network performance. It is expected that pedestrians will not consider it too onerous to walk 130m to a signalised intersection. Exceptions to this requirement may be granted by the Manager Network Operations.

## 14.2 ONE-STAGE CROSSINGS

A one-stage marked foot crossing is used on roads where there is no median or the median is less than 2.4 m wide. A typical design layout is shown in Figure 14.1 and drawing No. VD002-20. A two-phase post-mounted controller is adequate for these installations. If the crossing distance is greater than 25 m, then median lanterns must be provided. Irrespective of the crossing distance, if median posts are provided, push buttons must also be provided and these may be on Type 13, short push button posts.

The phase which allows the vehicle movements is A phase. The phase which allows the pedestrian movement is B phase. The vehicle lanterns are labelled V1 for one direction and, V2 for the other. The pedestrian lanterns are labelled P1.

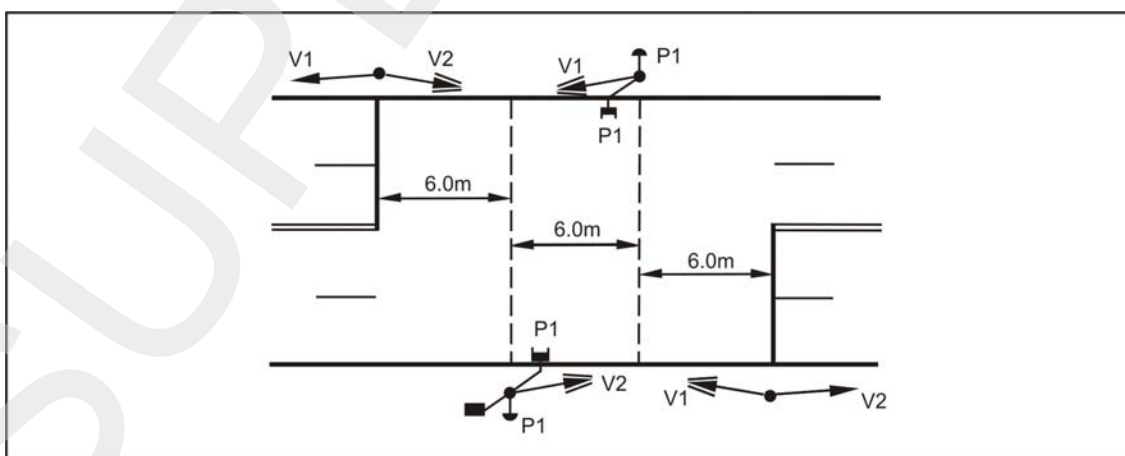

Figure 14.1 One-stage crossing

### 14.3 TWO-STAGE (OFFSET) CROSSINGS

The installation of a one-stage marked foot crossing on carriageways with wide medians (2.4 m or more) may cause excessive vehicle delays resulting from lengthy pedestrian clearance intervals. At sites where long marked foot crossings are a problem, a two-stage crossing should be considered. This allows improved traffic signal coordination under SCATS and reduces traffic delays by using a special two-stage two-phase controller utilising:

- offset and independent (two-stage) marked foot crossings
- call-ahead features to provide pedestrian progression
- concurrent pedestrian movements if both are demanded

Given the layout in Figure 14.2, pedestrian progression is achieved as indicated in the adjacent sequence table. The kerbside lanterns must be aimed or screened so that they are not visible to pedestrians on the opposite side of the road. Adequate drainage from the median is also essential.

In order to improve pedestrian safety, pedestrian fencing must be provided, in accordance with the current RTA practice, on the median and may be installed on the kerb if considered necessary. The fencing seeks to prevent pedestrians from "short-cutting" between the crossings, and also assists pedestrians in sighting the second stage pedestrian lantern.

The left-hand offset shown in Figure 14.2 is preferred to the right-hand offset shown in Figure 14.3 as it provides better sighting especially for pedestrians as they walk towards oncoming traffic. With the right-hand offset, the fence may obscure pedestrians from motorists. However, this effect can be minimised by using special fencing and, depending on the fencing used, tapering it at approximately 4 degrees for a minimum of 6m between the stop line and the marked foot crossing.

For relatively narrow medians, 2.4 m to 3.5 m wide, it may be beneficial to stagger the median posts to better distribute pedestrians in the available median space between the median posts. Whereas, in wider medians, 3.5 m or more, this is not so important and median posts can be more aligned.

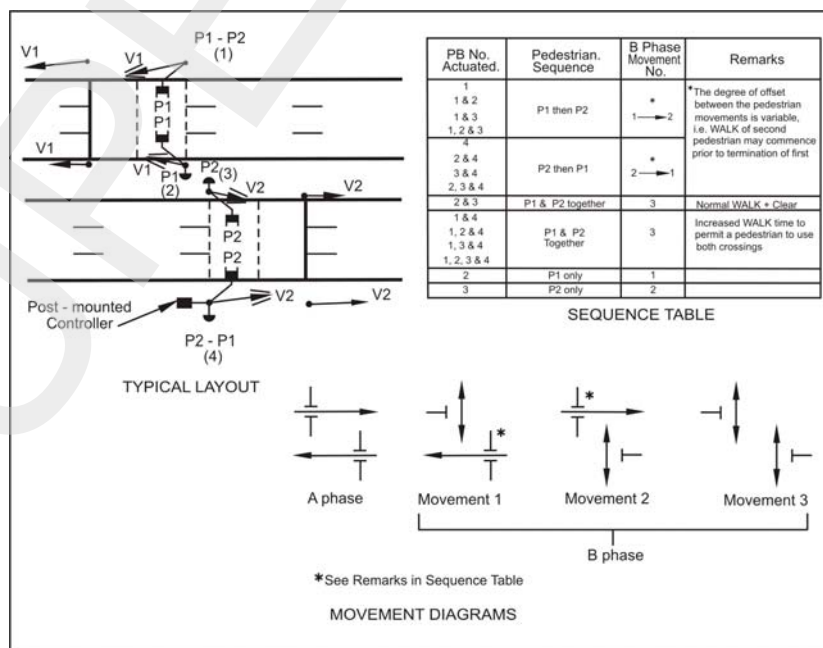
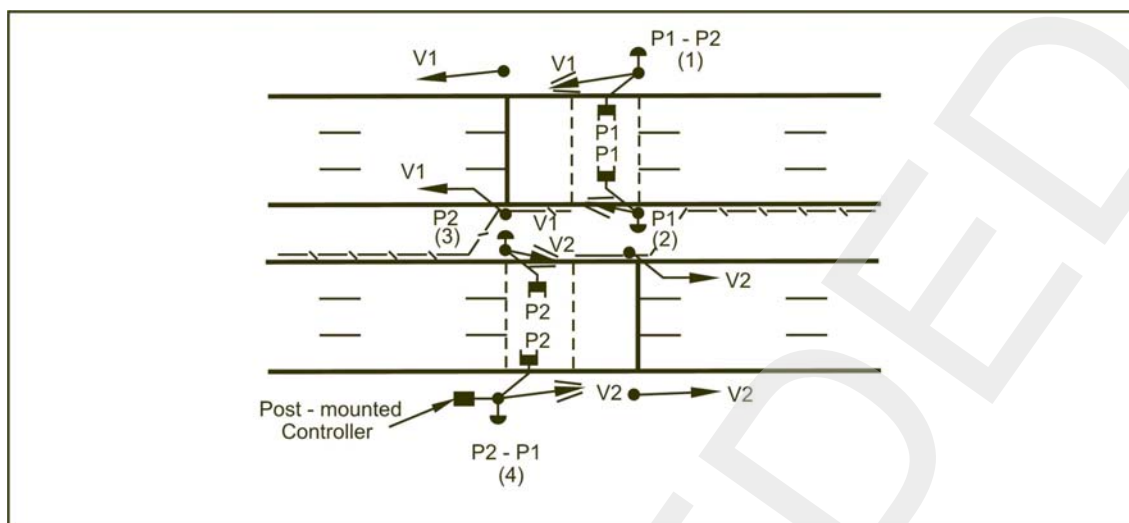

Figure 14.2 Two-stage crossing with left-hand offset



**Figure 14.3 Two-stage crossing with right-hand offset**

Note: Where loop detectors are to be included in a mid-block design the numbering of the push buttons must follow the loop detector numbers i.e. the loops are always numbered first.

The installation of a two-stage marked foot crossing may also be considered at signalised intersections with wide medians that are greater than 2.4m. See Section 15.18 in [Special Situations](#).

## 14.4 PELICAN CROSSINGS

The PELICAN crossing has been developed to help reduce vehicle delays normally associated with one-stage crossings. At a one-stage crossing, the motorist sees a red signal during the pedestrian walk and clearance intervals. PELICAN crossings differ from this in that the motorist sees a red signal for the Walk and Clearance 1 interval and flashing yellow for the Clearance 2 interval. The Clearance 1 interval can be varied to give varying degrees of protection, but should not be less than two seconds. The flashing yellow signal directs the vehicle to proceed if there is no conflict with pedestrians on the crossing.

The PELICAN crossing benefits the motorist by reducing the time spent waiting at a red signal. This allows a reduction in the cycle time and hence benefits pedestrians by providing a shorter waiting time for a walk signal or leads to a greater vehicle capacity without changing the cycle time (see Section 2.5 in [Warrants](#)).

The design layout for a PELICAN crossing (i.e. geometry, linemarking and location of traffic signal components) is the same as that for a one-stage crossing. See Figure 14.1 for the typical design layout.

PELICAN crossings are not to be installed on roads with 2 or more marked travel lanes in the same direction. This also applies to roads with 2 unmarked travel lanes in the same direction i.e. where vehicles can pass other vehicles travelling in the same direction. PELICAN crossings must not be installed at sites used predominantly by children, the elderly or people with disabilities or in an area where the speed limit is greater than 60 km/h.

PELICAN crossings can be provided by the provision of linemarking or kerb extensions which restrict the road to one travel lane each way, or where full time kerbside parking exists.

The vehicle signal groups should be labelled V1 and V2, where the V1 signal group is determined by the first primary lantern encountered in a clockwise direction from the controller. The pedestrian signal group and push buttons should be labelled P1.

When a PELICAN crossing feature is required a note should be included on the design plan to mention that the site is to operate as a PELICAN crossing either full or part time by the application of a Z- function in SCATS. The V1 and V2 signal groups are displayed concurrently.

**Time settings for the operation of PELICAN crossings are given in *Traffic Signal Operation – No: RTA – TC - 106.***

[Inside rear cover  
– provided for double sided printing purposes only]

SUPERSEDED

SUPERSEDED

---

**For further enquiries**

**[www.rta.nsw.gov.au](http://www.rta.nsw.gov.au)**

**13 22 13**

---

Roads and Traffic Authority

March 2008

RTA/Pub. 08.092